

## Kenanga Sustainability Series: Frontier Fund (KSSFF) Newsletter

June 2025

---

### FOREWORD BY THE TARGET FUND MANAGER

Before quantum computers, classical computers could only achieve speedups that grew steadily, not explosively. They got much faster by boosting clock speeds and doing more tasks at once, but this was still a scaled-up version of the same old method. This push for more power, especially with the Artificial Intelligence (AI) boom driving a million-fold increase in demand since 2012, fuelled rapid chip advancements and specialized accelerators, giving rise to companies like Nvidia.

Quantum computing, however, is a game-changer. It is the first new computing approach since the 1930s that could fundamentally change how computers work. Quantum computers could make certain tasks much easier, solving problems that were previously almost impossible. For example, simulating complex systems in physics and chemistry could become much simpler. Even in finance, quantum computers can speed up complex calculations: according to JP Morgan, for option pricing, the classical Monte Carlo simulation needs millions of samples, but its quantum counterpart achieves dramatic speedup with only a few thousand samples.

Beyond this, the world of quantum technology is rapidly evolving, with advancements that promise to revolutionize a plethora of use-cases across many industries. From the world's first commercial flight with GNSS-free navigation, to provably-secure communications over 3,800km, to realizing viable cancer drug candidates, quantum technologies are set to revolutionize many sectors. Most notably, BCG analysis estimates that quantum computing could create value of USD 450 billion to USD 850 billion in the next 15 to 30 years.

Nevertheless, with quantum computing relatively still being at an innovative stage, currently, there is no set global standard for technology readiness levels for quantum technologies, so understanding the capabilities of computing, communications, networking, and sensing can be confusing. This Newsletter provides an in-depth exploration of the principles of quantum computing, recent breakthroughs in the field, and the vast potential opportunities that quantum technology is poised to unlock over the next few decades.

*Source and notes:*

*National Academies of Sciences, Engineering, and Medicine, JP Morgan Chase, BCG Analysis, Qureca*

## TARGET FUND'S ASSET ALLOCATION

Cash and Equivalents

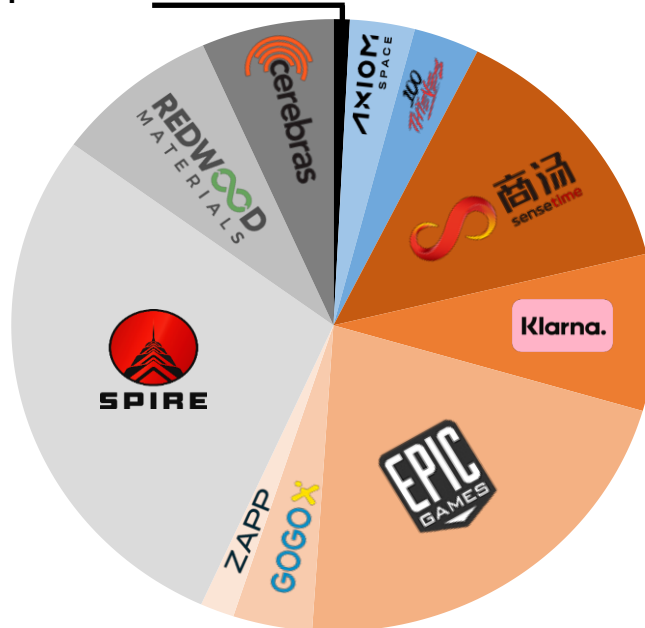

As of Q2 2025, the Target Fund has fully divested Paytm and Anduril positions

## TARGET FUND PORTFOLIO ASSET UPDATE

**Last Market Capitalization:** USD 7.02 billion as of 30 June 2025

**Updates:** Investment of USD 4.47 million in common shares at an approximate valuation of USD 12.68 billion.



- A leading artificial intelligence (AI) pioneer in China that specializes in computer vision and deep learning technologies.
- FY2024 revenue increased 10.8% year-on-year (YoY) to USD 526.87 million driven by a 103.1% YoY surge in Generative AI segment (63.7% of total revenue). Net losses also narrowed by 33.7% to USD 601.52 million.
- Unveiled the "SenseNova V6" and 'V6 Reasoner' AI foundation model, which notably substantially outperformed GPT-4o in data analysis capabilities.
- Introduced "SenseCore 2.0", its AI infrastructure platform, driving deep integration of AI infrastructure with application development and industry needs.
- Announced plans to boost its computing capacity over the next two years, where in 2024, the company reported a 92% YoY increase in computing power, reaching over 23,000 petaflops.

Note: Information as of 30 June 2025  
Source: News Articles, Capital IQ

**Last Market Capitalization:** USD 29.88 million as of 30 June 2025

**Updates:** Investment of USD 1.28 million in common shares at an approximate valuation of USD 1.50 billion.



- Asia's first app-based intra-city logistics platform that operates across Chinese mainland, Hong Kong, India, Singapore, South Korea and Vietnam.
- FY2024 revenue decreased by 12.3% YoY to USD 92 million primarily due to strategic adjustments in the Chinese mainland and shifting to Hong Kong and overseas markets that increased 5.8% YoY and accounts for 74.8% of the group's revenue.
- EBITDA FY2024 was at USD -12 million, an increase by 64.7%, and net income significantly improved by 82.6% YoY.
- Acquired a target company (unnamed company in the AI software sector, particularly in enterprise automation and conversational AI) for HKD 11.9 million, a strategic move to expand its business operations.

**Last Raised Valuation:** USD 2.42 billion as of 21 August 2023

**Updates:** Investment of USD 1.05 million in common shares at an approximate valuation of USD 2.41 billion.



- The leading provider of human spaceflight services and will build the world's first commercial space station.
- Successfully launched its Ax-4 human spaceflight mission to the International Space Station (ISS), Axiom's first break-even mission. The crew plans to spend around 2 weeks at the ISS and conduct more than 60 scientific experiments and demonstrations.
- Promoted Tejpal Bhatia from Chief Revenue Officer to Chief Executive Officer. He previously led key commercial spaceflight missions and high-profile partnerships with Prada and Nokia.
- Announced they will launch two Orbital Data Center (ODC) nodes to low-Earth orbit by end-2025, enabling secure space-based cloud computing & AI/ML for defence & commercial users, backed by up to USD 5.5 million from the Texas Space Commission.
- Signed a Memorandum of Understanding with the Egyptian Space Agency to establish a framework for joint initiatives, including research activities and support for human spaceflight efforts.

*Note: Information as of 30 June 2025  
Source: News Articles, Capital IQ*

**Last Raised Valuation:** USD 5.30 billion as of 29 August 2023

**Updates:** Investment of USD 2.68 million in common shares at an approximate valuation of USD 5.51 billion.



- The leading battery recycling firm in the US founded by former Tesla co-founder and Chief Technology Officer JB Straubel.
- Opened a 15,000 sq ft R&D center in San Francisco to deepen cathode innovation and scale engineering teams.
- Became exclusive battery recycler for Lime in the U.S., Germany, and Netherlands, scaling recovery for e-bike and scooter batteries with 95% – 98% yield.
- Launched Redwood Energy, a new business leveraging the thousands of Electronic Vehicle (EV) batteries it has collected to power AI data centers, starting with a partnership with Crusoe, a key player in OpenAI's Project Stargate.

**Last Raised Valuation:** USD 6.70 billion as of 11 July 2022

**Updates:** Investment of a total of USD 2.66 million in common shares at an approximate valuation of USD 35.11 billion.

**Klarna.**

- Founded in Sweden, Klarna is popular alternative payment provider that enables shoppers to split purchase in installments through “buy now, pay later” financing.
- Q12025 revenue rose 15% YoY to USD 701 million, with a 4<sup>th</sup> straight adjusted operating profit at USD 3 million, highlighting improving margins and scalability.
- Launched waitlist for Klarna’s mobile phone service in the U.S. via AT&T partnership, marking its first step into telecom.
- Reached 100 million active users in Q12025, the fastest growth rate in 2 years, supported by Stocard integration and U.S. expansion.
- Merchant count rose 27% quarter-on-quarter (QoQ) to 724,000, driven by Stripe integration, with further expansion expected through upcoming JPMorgan, Worldpay, and Nexi rollouts.
- Introduced an AI customer support chatbot modeled after CEO, now live in the U.S. and Sweden; customer service cost per transaction down approximately 40% vs. Q12023.

*Note: Information as of 30 June 2025  
Source: News Articles, Capital IQ*

**Last Raised Valuation:** USD 31.50 billion as of 11 April 2022

**Updates:** Investment of USD 6.94 million in common shares at an approximate valuation of USD 25.47 billion.



- The leading interactive entertainment company providing an end-to-end digital ecosystem for developers and creators to build, distribute, and operate games and other content.
- Acquired Loci, an AI platform for automated tagging 3D assets, which will be integrated across the Epic ecosystem to improve search, sharing and discoverability of 3D content, along with helping to identify potential IP violations.
- Apple has failed to convince the US appeals court to pause key provisions of a previous federal ruling, which requires the company to allow external payment options in its App Store – enabling customers to pay Epic Games directly.
- Updating its store to offer 0% revenue share on the first USD 1 million per app annually and let developers launch webshops for lower-cost out-of-app purchases with 5% rewards for players to improve Epic's competitive position as a game distributor.

**Last Raised Valuation:** USD 0.46 billion as of 2 December 2021

**Updates:** Investment of USD 1.05 million in common shares at an approximate valuation of USD 0.52 billion.



- A premier lifestyle brand and gaming organization founded by former professional gamer, Matthew "Nadeshot" Haag.
- Announced a new multi-category partnership with Razer, a leading lifestyle brand for gamers, as their official headset, controller and chair partner across their esports teams.
- Released their third Adidas x 100 Thieves drop, this time in collaboration with world champion sprinter, Noah Lyles, which features clothes such as pants, t-shirts, liners, and hoodies, combining outdoor gear with lifestyle comfort.
- Entered the Street Fighter esports scene with the signing of Sean 'Shine' Simpson, a respected figure in the fighting game community and a consistent contender on the global stage.

*Note: Information as of 30 June 2025  
Source: News Articles, Capital IQ*

## ZAPP

**Last Raised Valuation:** USD 0.34 billion as of 20 January 2022

**Updates:** Investment of USD 0.50 million in common shares at an approximate valuation of USD 0.33 billion.

- Operates an online delivery platform that provides on-demand delivery of groceries in London and Manchester, UK.
- Surpassed USD 100 million in sales in 2024, with operating margins exceeding 15% and an average order value above USD 50.
- Launched new sites in North Kensington and Earls Court. These strategic locations allow the company to better serve high-demand areas while providing additional capacity for future growth.
- Expanding to Dubai as early as this year, having already hired local talent and engaged in partnership talks with Talabat Holding Plc and Careem.

**Last Raised Valuation:** USD 4.30 billion as of 10 November 2021

**Updates:** Investment of USD 2.14 million in common shares at an approximate valuation of USD 1.88 billion.

## cerebras

- A leading innovator in high-performance AI hardware, pioneering the development of the world's largest and fastest AI processors. Offering AI hardware and extended cloud services to leading research institutions.
- Along with Canadian chip startup Ranovus have been awarded a USD 45 million contract from the US military to speed up connections between computing chips.
- Announced as the official launch partner for Llama 4, Meta's most powerful Llama model to date and Cerebras is currently the fastest Llama 3.3 provider in the world.
- Meta has also teamed up with Cerebras to launch its Llama API, offering developers up to 18x faster inference speeds than traditional GPU-based solutions, to compete with OpenAI, Anthropic, and Google.
- Bit Digital secured a new Québec data center site (MTL-3) to power its 5MW deal with Cerebras, targeting a July 2025 launch at CAD 55 million (~USD 40 million) development cost.
- ZS, a global management consulting firm, has partnered with Cerebras to integrate its CS-3 systems into ZS's MAX.AI platform, enabling high-performance AI model training and deployment.
- Independent benchmarks by Artificial Analysis show Cerebras achieving over 2,500 TPS/user on Meta's Llama 4 Maverick, more than doubling Nvidia's flagship DGX B200 (8 Blackwell GPUs) at 1,000 TPS/user.

*Note: Information as of 30 June 2025*

*Source: News Articles, Capital IQ*

## QUANTUM COMPUTING: WHAT EXACTLY IS IT?



'Quantum Physics' – Is the study of the behavior of matter and energy at the smallest scales - typically atoms and subatomic particles like electrons and photons. This branch of physics, which emerged in the late 20<sup>th</sup> century is looking to set a new industry standard for computing.

**Classical computing** primarily process information using **bits**, a unit of information that can store **either 0 or 1**. In contrast, a **quantum computer** utilizes **qubits**, which can be any superposition **between 0 and 1, inclusive of both**, thanks to quantum physics. Thus, when data are input into the qubits, the qubits interact with other qubits, allowing for many different calculations to be run simultaneously; this is why quantum computers can work so much faster than classical computers. To further understand how quantum computers exploit these inherent properties of quantum particles, the 4 principles of quantum mechanics are studied, Superposition, Decoherence, Interference, and Entanglement.

**4 Principles Explanation – As describing the behaviors of quantum particles presents a unique challenge, consider a Maze:**

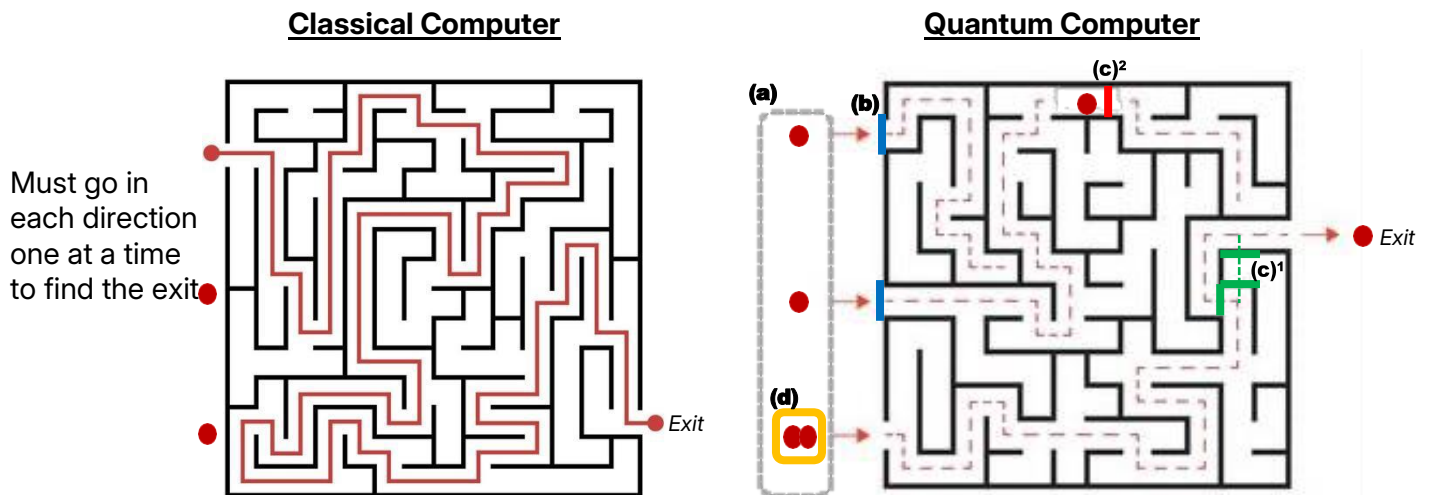

**(a) Superposition:**



Suppose the red dots are qubits that can go in all directions at the same time, and thus with more 'qubits' the faster the problem can be solved.

**(b) Decoherence:**



While simultaneously exploring all paths, if the red dots accidentally bump into a wall, or interfered by outside noise, its 'superposition' collapses.

**(c) Interference:**



Constructive interference **(C)<sup>1</sup>** amplifies the correct route to a path closer to the exit, whereas Destructive interference **(C)<sup>2</sup>** cancels out incorrect paths or dead ends.

**(d) Entanglement:**



Two or more red dots (qubits) become intrinsically linked, so the state of one instantly affects the state of the others, regardless of distance.

Source: IBM, Qureca, McKinsey, Wecomunications, Ericsenz

## BRINGING THEORY TO REALITY – A GAME CHANGER TO COMPUTATION

### How are Quantum Computers Built and What Makes it so Special?

Unlike classical computers that use transistors, quantum computers require highly specialized hardware. The main components include:

- **Quantum Architecture:** Represents the quantum error correction units and the physical qubits themselves.
- **Quantum Gates:** Performs the actual computations by manipulating the states of the qubits in the quantum architecture.
- **Electronic Writing & Reading:** Acts as interfaces, translating signals from the Classical Computer into control signals for the quantum gates.
- **Measurement Interface:** Reads the final state of the qubits from the quantum register after computations are complete.

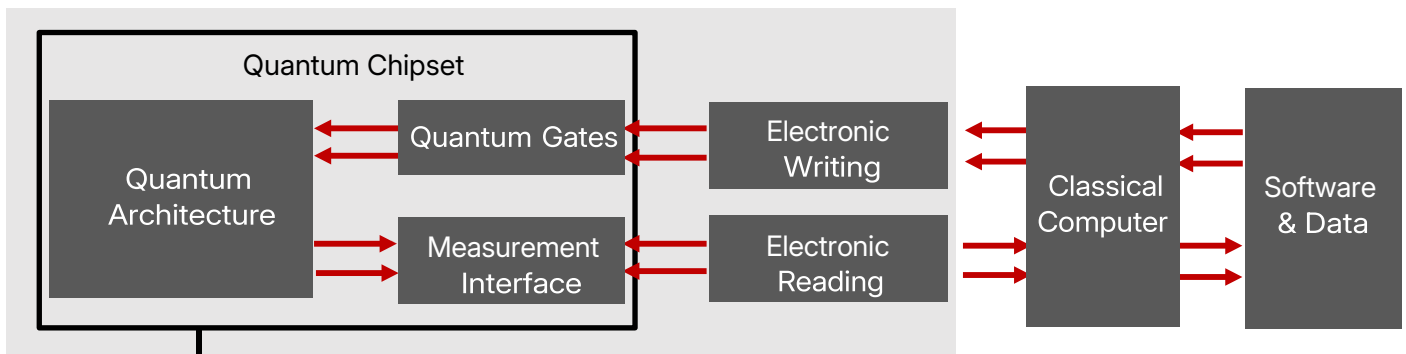

The Quantum Chipset is housed by a chamber with a cryogenic cooling systems that operates at near absolute zero,  $-273^{\circ}\text{C}$ , colder than the interstellar space.

The IBM Q, chamber operating at around  $-273^{\circ}\text{C}$



In 2019, Google's Sycamore, a **53 qubit** quantum computer, solved a complex math problem in 200 seconds - a task that would take the world's fastest supercomputer 10,000 years to complete.

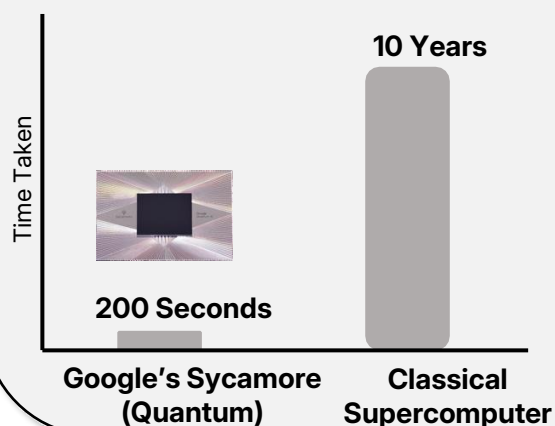

In 2025, Microsoft showcased, the Majorana 1 chip, designed to scale to **1 million qubits** on a single chip displaying...



...a major advancement beyond an already revolutionary technology.

Source: National Academies of Sciences, Engineering, and Medicine, Company Websites, News Articles

## KEY TECHNOLOGIES – FIVE MAIN QUBIT TECHNOLOGIES

Despite recent breakthroughs, quantum computing is still in its early stages, with challenges in error correction, qubit stability and scalability. As such, we are currently in the stage commonly known as the “NISQ” era, for Noisy Intermediate Scale Quantum technology, where systems of qubits have yet to be “error-corrected,”. Organizations are mainly using 5 qubit technologies in their attempts to build a scalable, universal quantum computer. These technologies are photonic networks, superconducting circuits, spin qubits, neutral atoms, and trapped ions:

### McKinsey Study on Total Funding for the 5 Main Qubit Technologies:

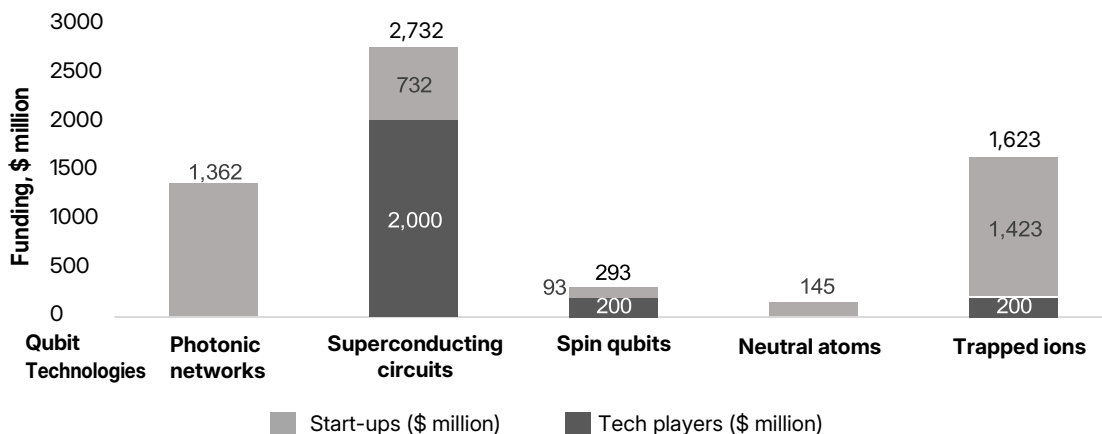

### Key Players

Superconductors is the technology adopted by Google, AWS, and IBM, gathering 44% of global investments in quantum. While it is not clear which technology will win the race yet, the quantum world might in fact live with a combination of different machines. Below is a mapping of this market and the key pros and cons:





<p><b>Superconducting</b></p>	<ul style="list-style-type: none"> <li>• <b>Artificial qubits:</b> Circuit loop with an electrical current traveling around it</li> <li>✓ Mature manufacturing process</li> <li>✓ Scalability</li> <li>✗ Near absolute zero temperatures</li> <li>✗ Connectivity limitation in 2D</li> </ul>	<p><b>Trapped Ions</b></p>	<ul style="list-style-type: none"> <li>• <b>Natural qubits:</b> Atoms with a net electrical charge that are trapped and manipulated using electric and magnetic fields</li> <li>✓ High fidelity (long coherence times)</li> <li>✗ Distant ions cannot interact directly</li> <li>✗ Require large and specialized infrastructure</li> </ul>
<p><b>Photons</b></p>	<ul style="list-style-type: none"> <li>• <b>Artificial qubits:</b> Particles of light</li> <li>✓ Horizontal scalability</li> <li>✓ Established semiconductor tech</li> <li>✗ Sensitive to external noise (decoherence)</li> </ul>	<p><b>Neutral</b></p>	<ul style="list-style-type: none"> <li>• <b>Natural qubits:</b> Neutral atoms suspended in an ultrahigh vacuum by arrays of tightly focused laser beams called optical tweezers</li> <li>✓ Horizontal scalability</li> <li>✓ Connectivity</li> <li>✗ Slower gate operations</li> <li>✗ Sensitive to external noise (decoherence)</li> </ul>
		<p><b>Spin Qubits</b></p>	<ul style="list-style-type: none"> <li>• <b>Natural qubits:</b> Single electrons trapped in double quantum dots</li> <li>✓ Stability with long coherence times</li> <li>✓ Connectivity</li> <li>✗ Low fidelity</li> <li>✗ Nascent engineering</li> </ul>

Source: National Academies of Sciences, Engineering, and Medicine, Company Websites, BCG Analysis, News Articles

## QUANTUM VALUE CHAIN - APPLICATIONS FROM QUANTUM COMPUTING AND VALUE CREATION

### Quantum-Advantaged Mathematical Functions

Quantum computers will likely not replace traditional computers, but will work together to solve complex problems that classical computers cannot handle quickly. While there is no consensus on the exhaustive set of problems that quantum computers will be able to tackle, but research is concentrated on the following 4 types of computational problems:

<p><b>Simulation</b> </p> <p>Modelling complex natural phenomena beyond classical computers' reach. e.g. Quantum-powered sensors enable satellite-free navigation by measuring motion with extreme precision.</p>	<p><b>Optimization</b> </p> <p>Using quantum algorithms to identify the best solution among a set of feasible options. e.g. Volkswagen used quantum computing to optimize traffic flow in cities, reducing congestion and travel times.</p>
<p><b>Machine Learning</b> </p> <p>Identifying patterns in data to train ML algorithms, accelerating development in AI. e.g. Banks are testing quantum machine learning prototypes for enhanced risk modeling and fraud detection.</p>	<p><b>Cryptography</b> </p> <p>Breaking traditional encryption and enabling stronger encryption standards. e.g. Reportedly there is 50% chance quantum computers will crack RSA-2048 (considered the gold standard for public key encryption) by 2031.</p>

### Value Creation Potential for Quantum Computing Problem

BCG estimates that quantum computing could create value of USD 450 billion to USD 850 billion in the next 15 to 30 years. With industries in Finance and Pharma likely to see the most value.

	Applications	Value creation potential (\$B)	
		Low	High
Cryptography (\$40-\$80B)	Encryption/decryption	\$40	\$80
Optimization (\$100-\$220B)	Aerospace: Flight route optimization	\$20	\$50
	Finance: Portfolio optimization	\$20	\$50
	Finance: Risk management	\$10	\$20
	Logistics: Vehicle routing/network optimization	\$50	\$100
Machine learning (\$150-\$220B)	Automotive: Automated vehicle, AI algorithms	\$0	\$10
	Finance: Fraud and money-laundering prevention	\$20	\$30
	High tech: Search and ads optimization	\$50	\$100
	Other: Varied AI applications	\$80+	\$80+
Simulation (\$160-\$330B)	Aerospace: Computational fluid dynamics	\$10	\$20
	Aerospace: Materials development	\$10	\$20
	Automotive: Computational fluid dynamics	\$0	\$10
	Automotive: Materials and structural design	\$10	\$15
	Chemistry: Catalyst and enzyme design	\$20	\$50
	Energy: Solar conversion	\$10	\$30
	Finance: Market simulation (e.g. derivatives pricing)	\$20	\$35
	High tech: Battery design	\$20	\$40
	Manufacturing: Materials design	\$20	\$30
	Pharma: Drug discovery and development	\$40	\$80

Source: National Academics of Sciences, Engineering, and Medicine, Company Websites, News Articles

## THE DEVELOPMENT STAGE – RECENT DEMANDS AND GLOBAL INITIATIVES

### Current Demand for Quantum Technologies

The quantum computing sector has seen a flurry of significant contracts and collaborations recently, reflecting growing interest from governments, defence, and various industries. Below is a summary of recent major announcements, focusing on late 2024 and 2025:



### Global Government Engagement with Quantum Technologies

With such vast value creation potential, the global quantum effort in research and innovation into quantum science and technology is continually rising with current worldwide investments exceeding USD 55.7 billion. While much is still unknown, China is believed to be one of the leading nations in quantum information science.

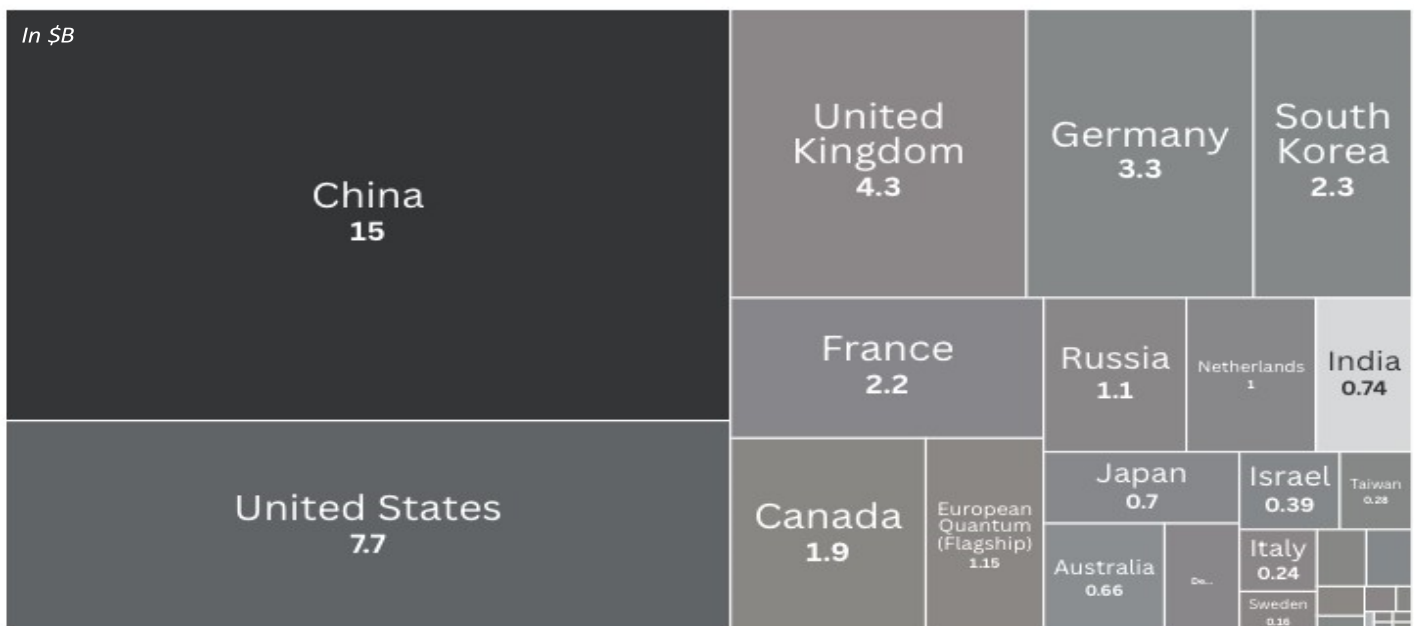

Source: National Academies of Sciences, Engineering, and Medicine, Qureca, News Articles

## CHALLENGES WITHIN QUANTUM COMPUTING

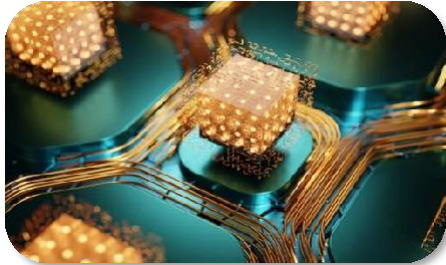

### Hardware: Still Prone to Decoherence

Improvement in qubit coherence and error correction is essential for future scalability, to which quantum hardware is constantly evolving and the 'correct path' is still unclear.

In contrast to the 5 main quantum technologies shown earlier, Microsoft's Majorana 1 chip distinguishes itself leveraging a new class of materials called "topoconductors" (indium arsenide and aluminum).



### Software: Need to Work With Classical Computers

To unlock near-term applications, hybrid quantum-classical algorithms need accelerated development.

For example, Zapata AI's "Orchestra" platform lets chemists mix quantum and classical computing to simulate molecules for drug discovery on a platform that is familiar to them.



### Infrastructure: Need Integration in Data Centers

Quantum computers must integrate into classical data centers to meet user demands.

For example, AWS Braket partners with Rigetti and IonQ to offer quantum cloud access alongside classical HPC in hybrid data centers.

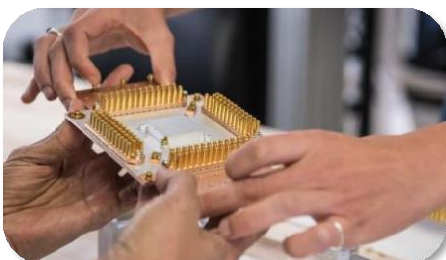

### Talent: Limited Workforce Availability

There is a shortage of skilled workers in quantum computing, requiring training programs and private sector partnerships.

For example, US NQI funds "Q-12" education partnerships, while companies like Quantinuum offer certification programs for quantum programmers.

Source: National Academies of Sciences, Engineering, and Medicine, Company Websites, News Articles

## INVESTMENT IMPLICATIONS

### Publicly Traded Pureplay Opportunities

For investment opportunities, there are different ways to play quantum computing. One is to focus on big-cap, but the impact of quantum computing technology on their income statements and balance sheets is largely muted because they have other large revenue streams. Hence, quantum technology companies recognised for their research and successful developments are highly sought after by investors.

**Big-Cap**

**Publicly Traded Pureplay Stocks**

### Publicly traded pureplay stocks performance to date:

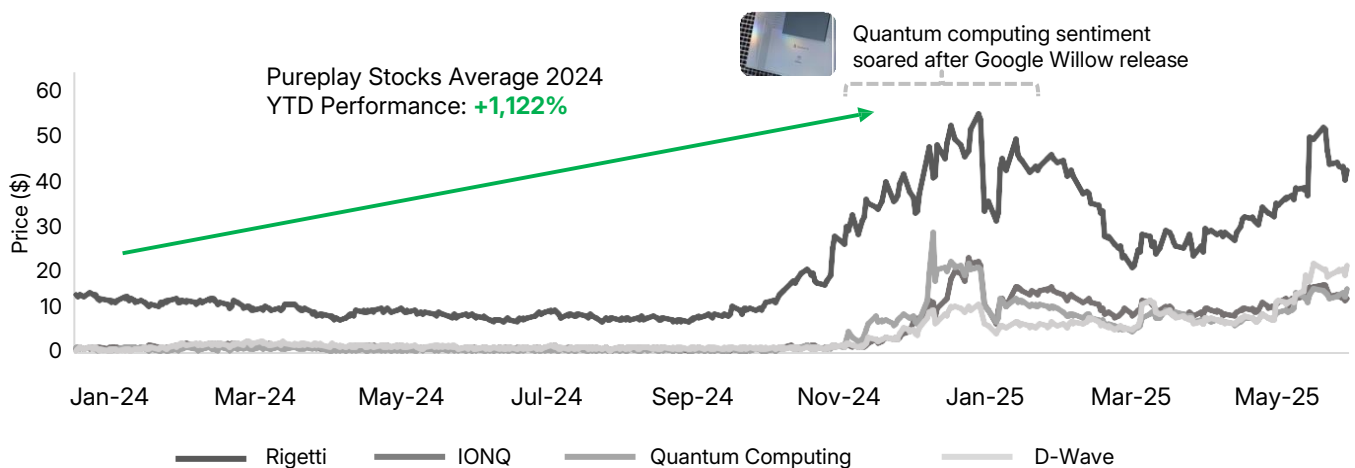

### How to Play? – Quantum Computing ETFs

While early leaders show promise, BCG predicts quantum advantage by ~2030 and full fault-tolerant computers available post-2040. With quantum computing still in its early stages, investors may prefer broad exposure via ETFs like Defiance Quantum ETF (QTUM), which targets quantum and AI focused companies.

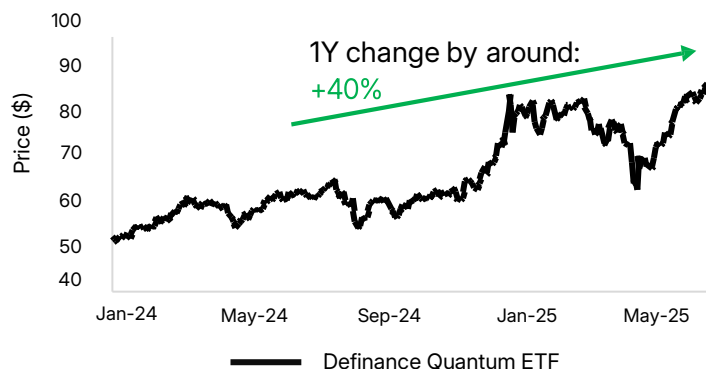

Top5 Holdings	Percentage of ETF
D-Wave Quantum	7.63%
Palantir Technologies	2.33%
NEC	2.06%
Rigetti Computing	2.02%
Orange	1.90%

For greater diversification in this speculative field, the ETF includes non-US companies, simplifying access to firms often difficult for individual investors to research due to foreign listings or reporting.

Source: Ericsenz Analysis



**Kenanga Investors**

#### **Disclaimer**

This document is a marketing presentation prepared by Kenanga Investors Berhad (KIB) and is strictly for discussion and informational purposes for sales staff only. It should not be circulated to any third party without prior approval from KIB. The information provided herein, including any expressions of opinion or forecasts, has been obtained from or is based on sources believed by us to be reliable. However, no representation or warranty, express or implied, is given with respect to the accuracy, completeness, sufficiency, or usefulness of the information, or that any future transaction will conform to the terms herein. Any decision to proceed with a transaction to which this information relates should be made solely in reliance upon final documentation agreed between us. This document does not constitute an offer to buy or sell or a solicitation of an offer to buy or sell any security or instrument or to participate in any particular trading strategy. Neither KIB nor any of its affiliates, directors, employees, agents, advisers, or any other person accepts any liability to any person in relation to the distribution, possession, or delivery of this document in, to, or from any jurisdiction.

Any projections or other estimates in this information, including estimates of returns or performance, are forward-looking statements based upon certain assumptions and are preliminary in nature. Actual results are difficult to predict and may depend upon factors within or beyond the issuer's or KIB's control. Actual events may differ from those assumed, and changes to any assumptions may have a material impact on any projections or estimates. Other events not considered may occur and may significantly affect the analysis. There can be no assurance that estimated returns or projections can be realized or that actual returns or performance results will not be materially lower than those estimated herein. Such estimated results, returns, and projections should be viewed as hypothetical and do not represent the actual results/returns that may be achieved. Price and product availability are deemed to be indicative only and are subject to changes at any time without notice. You should also consider the fees and charges involved before investing.

The current Information Memorandum dated 27 October 2021 has been lodged with the Securities Commission Malaysia ("SC"), who takes no responsibility for its contents and related advertisements or marketing materials. This does not indicate that the SC has recommended or endorsed the product/service. The advertisement has not been reviewed by the SC. Investors have the right to request for a copy of the PHS and other relevant product disclosure documents which are available at our office, any authorised distributors, and our corporate website before making an investment decision. A Fund's track record does not guarantee its future performance.

KIB/KIIB is committed to preventing Conflict of Interest between its various businesses and activities and between its clients/directors/shareholders and employees by having procedures and measures in place to identify and properly manage any apparent, potential, and perceived Conflict of Interest by making appropriate disclosures to clients.